

COUNTY	STATE	PROJECT NUMBER	FISCAL YEAR	SHEET NO.	TOTAL SHEETS
SEDGWICK	KANSAS	###	###	###	###

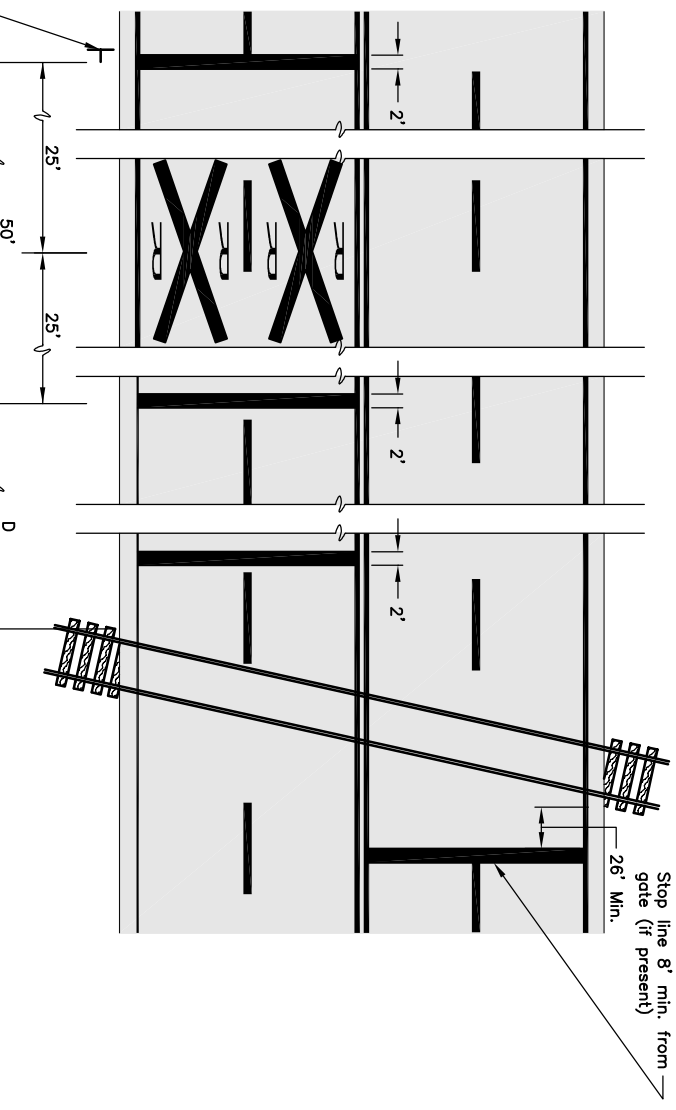

POSTED SPEED (MPH)	DISTANCE D (FEET)
85	500
60	500
55	500
50	500
45	400
40	350
35	300
30	250
25	250
20	250

ALL DISTANCES ARE MINIMUM

TYPICAL PAVEMENT MARKINGS AT RAILROAD GRADE CROSSINGS

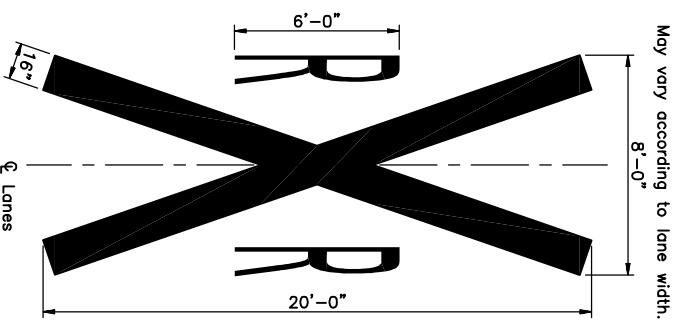

RAILROAD CROSSING SYMBOL

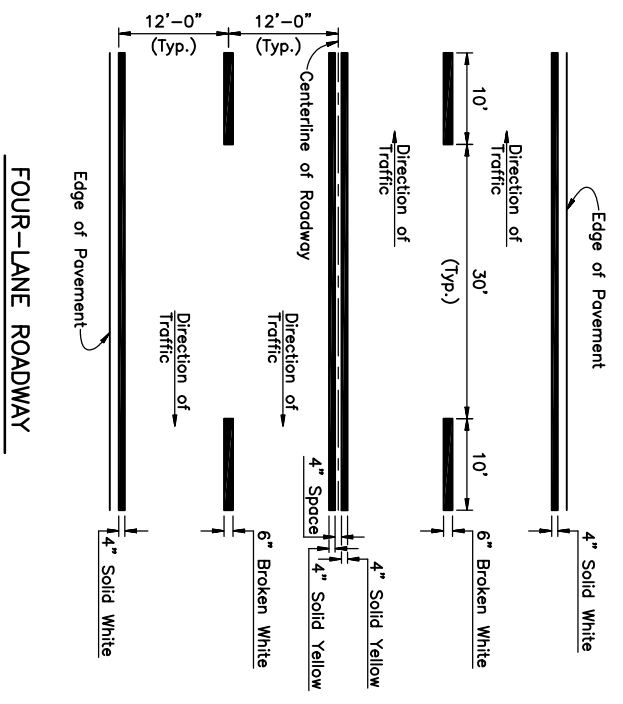

FOUR-LANE ROADWAY

ITEM	QUANTITY	UNITS
Pavement Marking (Thermoplastic)(White)(4")(0.090")		Lin.Ft.
Pavement Marking (Thermoplastic)(White)(6")(0.090")		Lin.Ft.
Pavement Marking (Thermoplastic)(Yellow)(4")(0.090")		Lin.Ft.
Pavement Marking (Methyl Methacrylate)(White)(4")(0.090")		Lin.Ft.
Pavement Marking (Methyl Methacrylate)(White)(6")(0.090")		Lin.Ft.
Pavement Marking (Methyl Methacrylate)(Yellow)(4")(0.090")		Lin.Ft.
Pavement Marking Symbol (Methyl Methacrylate)(White)(Left Arrow)		Each

BILL OF MATERIALS (For Information Only)

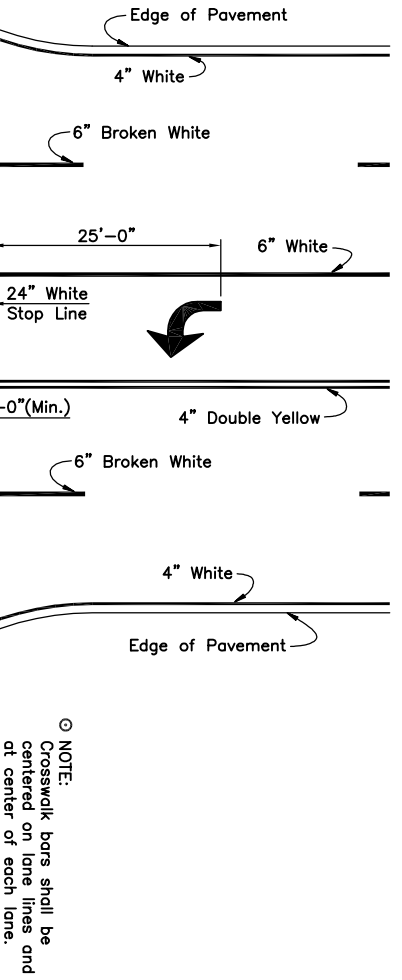

NOTE: Crosswalk bars shall be centered on lane lines and at center of each lane.

CROSSWALK MARKING PLAN
MULTI-LANE ROADWAY

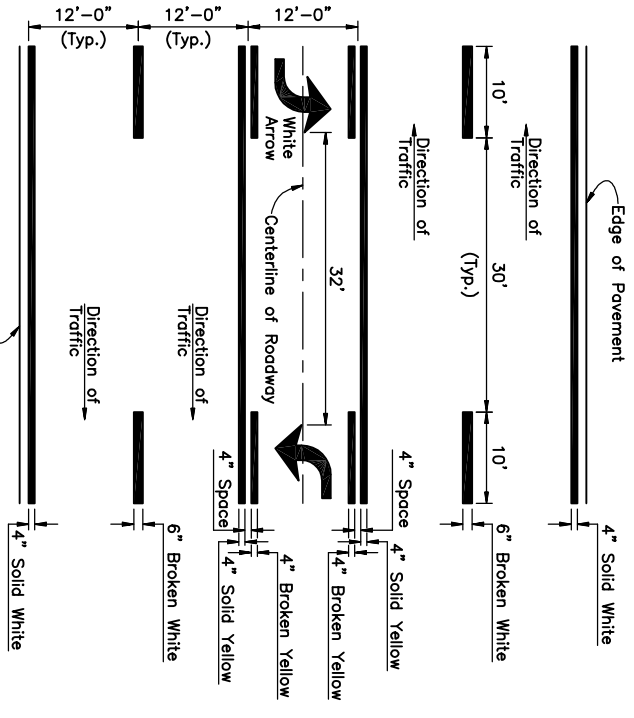

FIVE-LANE ROADWAY

PAVEMENT MARKING PLAN
MULTI-LANE ROADWAYS
WITHOUT CURB & GUTTER

2/16/06	Revised Bill of Materials/Removed SI Option	DRS/MRB
Rev/Date	Description	By/Chk

PREPARED BY
 SEDGWICK COUNTY PUBLIC WORKS
 HIGHWAY DEPARTMENT

DAVID C. SPEARS, P.E.
 DIRECTOR/COUNTY ENGINEER

REVISED	SCALE	DESIGNED	INCH	CHECKED	SHEET NO.
NONE	NONE	M.R.B.	D.R.S.	M.R.B.	###
DATE	4/2005	4/2005	4/2005	4/2005	###

PM 2-0