



SEDGWICK COUNTY, KANSAS
DIVISION OF FINANCE
Purchasing Department
Joe Thomas, Senior Purchasing Agent

525 N. Main, Suite 823 ~ Wichita, KS 67203
Phone: 316 660-7265 Fax: 316 383-7055
www.sedgwickcounty.org/purchasing

REQUEST FOR BID
#09-0154
TRAFFIC SIGN BLANKS

May 21, 2009

Sedgwick County, Kansas (hereinafter referred to as County) will accept bids for Traffic Sign Blanks. This request for bid provides specifications, a general description of the details of submittal requirements, terms and conditions. **This bid will constitute contract pricing for one (1) year following award, with the potential for two (2) additional one (1) year options to renew, subject to approval by Sedgwick County. An official Purchase Order will be provided to the successful vendor.**

Please carefully review this document. If your firm is interested in participating in this selection process commensurate with the specifications, conditions, mandatory requirements, and instructions contained herein, return one (1) original and two (2) copies of the entire document and all supplementary materials **no later than Tuesday, June 9, 2009 at 1:45 p.m. (CDT) to Sedgwick County Purchasing Department, 525 N. Main, Suite 823, Wichita, KS 67203.** Late bids will not be accepted and will not receive consideration for final award.

Responses to this Request for Bid will be opened and read aloud at a public meeting held at 2:00 p.m. (CDT) Tuesday, June 9, 2009. You or your representatives are welcome to attend.

If you have any questions, please contact Joe Thomas, Senior Purchasing Agent, Sedgwick County Purchasing at 316-660-7265 or at jethomas@sedgwick.gov.

Joe Thomas, C.P.M.
Senior Purchasing Agent

REQUEST FOR BID CONDITIONS

In submitting a response to this Request for Bid, vendors hereby understand the following:

1. Pricing offered in the bid document will be provided to other local governments and governments whom Sedgwick County regularly enters into cooperative agreements.
2. Sedgwick County reserves the right to reject any and/or all bids and responses to these and/or related documents, to accept any item(s) in the bids, to waive any irregularity in the bids, and further if determined to be non-responsive in any form, or if determined to be in the best interest of Sedgwick County.
3. Alternate bids (two or more bids submitted) will be considered for an award. Sedgwick County reserves the right to make the final determination of actual equivalency or suitability of such bids with respect to requirements outlined herein. The bids submitted, and any further information acquired through interviews, will become and is to be considered a part of the final completed contract. If there is any variance or conflict, the bid specifications will control.
4. Bidders MUST return, completed copies of the entire document to the Sedgwick County Purchasing Department, 525 North Main, Suite 823, Wichita, KS 67203, on or before the date and time specified. Bids must be sealed in an envelope and marked with the firm name and address, bid number, bid opening date, and bid opening time. The time clock stamp, located in the Sedgwick County Purchasing Department will determine the time of receipt.
5. Bids submitted may not be withdrawn for a period of 60 days immediately following the opening of this Request for Bid. Prices MUST be free of federal, state, and local taxes unless otherwise imposed by a governmental body, and applicable to the material on the bid.
6. Sedgwick County interprets the term "Lowest Responsible and Best Bidder" as requiring Sedgwick County to: (a) choose between the kinds of materials, goods, wares, or services subject to the bid, and (b) determine which bid is most suitable for its intended use or purpose. Sedgwick County can consider, among other factors, such things as the availability of service(s), part(s) material(s) and/or supply(s), warranty, maintenance, freight costs, performance of product and labor cost of items upon which bids are received.
7. All requested information must be supplied. If bidders cannot respond to any part of this request, bidders should state the reason they cannot respond and note an exception. Bidders may provide supplemental information to assist Sedgwick County in analyzing its bid.
8. If the bidder refuses or fails to make deliveries of the materials within the times specified on the face of the Request for Bid or purchase order, Sedgwick County may, by written notice, terminate the contract or purchase order.
9. The bidder will warrant that goods, personal property, chattels, and equipment sold and delivered are free and clear of any and all liens, or claims of liens, for materials or services arising under, and by virtue of the provisions of K.S.A. Sections 58-201, et seq., and any other lien, right, or claim of any nature or kind whatsoever.
10. The successful bidder will hold and save Sedgwick County, and its officers, agents, servants/employees harmless from liability of any patented, or unpatented invention, process, article, or appliance manufactured, or used in the performance of the contract, including its use by Sedgwick County. Vendors working on county property or on behalf of County will be required to carry minimum insurance listed in bid document.
11. All items furnished, if applicable, must be the best of their respective kinds, and will be free from defects in material and workmanship. Items will be subject to County inspection and approval at any time within 30 days after delivery. If a substitution is made, it will be the decision of a Sedgwick County representative to determine if it is of equal quality. Items furnished must be manufactured in compliance with all existing legal or governmental directives.
12. Unless specified otherwise, all items bid are to be as a minimum but not necessarily limited to: new, current model year, and untitled prior to shipping and/or installation.
13. Sedgwick County is desirous of allowing as many vendors as possible the opportunity to participate including minority men and women-owned businesses, and small businesses in the roles of providing goods and services to Sedgwick County. If your company does not fall into any of these categories, your efforts to contract with vendors who do fall into these categories are appreciated. Construction projects utilizing subcontractors requires a subcontracting worksheet. Contact purchasing department for details.

14. Contracts entered into on the basis of submitted bids are revocable if contrary to law.
15. County reserves the right to enter into agreements subject to the provisions of the Cash Basis Law (K.S.A. 10-1112 and 10-1113), the Budget Law (K.S.A. 79-2935). Agreements shall be construed and interpreted so as to ensure that the County shall at all times stay in conformity with such laws, and as a condition of agreements the County reserves the right to unilaterally sever, modify, or terminate agreements at any time if, in the opinion of its legal counsel, the Agreement may be deemed to violate the terms of such law.
16. The Bidder agrees to comply with K.S.A. 44-1030.
 - a. The contractor shall observe the provisions of the Kansas act against discrimination and shall not discriminate against any person in the performance of work under the present contract because of race, religion, color, sex, disability, national origin or ancestry;
 - b. In all solicitations or advertisements for employees, the contractor shall include the phrase, "equal opportunity employer," or a similar phrase to be approved by the commission;
 - c. If the contractor fails to comply with the manner in which the contractor reports to the commission in accordance with the provisions of K.S.A. 44-1031 and amendments thereto, the contractor shall be deemed to have breached the present contract and it may be canceled, terminated or suspended, in whole or in part, by the contracting agency;
 - d. If the contractor is found guilty of a violation of the Kansas act against discrimination under a decision or order of the commission which has become final, the contractor shall be deemed to have breached the present contract and it may be canceled, terminated or suspended, in whole or in part, by the contracting agency; and
 - e. The contractor shall include the provisions of subsections (a) through (d) in every subcontract or purchase order so that such provisions will be binding upon such subcontractor or vendor.
17. All project participants, consultants, engineers, contractors and subcontractors, must comply with all applicable Federal, State and County laws pertaining to contracts entered into by governmental agencies. All participants must comply with the Americans with Disabilities Accessibility Guidelines (ADAAG).
18. Contractors/subcontractors performing new construction, maintenance, alterations, or additions to Sedgwick County buildings or facilities must comply with building guidelines/codes, and the Americans with Disabilities Accessibility Guidelines (ADAAG). Any violation of the provisions of the ADA or 504, or specification deficiencies, should be reported to the county's ADA coordinator. Failure to notify the county's ADA coordinator for remedy may be considered a breach of contract and may be grounds for cancellation, termination for suspension, in whole or in any part of the contract. All construction plans will have the county's ADA coordinator approval prior to beginning any work.
19. Contractors/vendors providing services to the public on behalf of Sedgwick County will agree that all personnel in their employment that have direct contact with the public will attend ADA Awareness and Sensitivity training provided by Sedgwick County or the Independent Living Resource Center. Training should be coordinated through the county's ADA coordinator, (316) 660-7052 and evidence of training shall be provided to the county's ADA coordinator. Any violations of the provisions of ADA or section 504, will be deemed a breach of contract and be subject to termination of contract.
20. The bidder responding to this bid solicitation proposes to furnish all materials, labor, supplies, equipment and incidentals necessary to provide the equipment/materials/services described herein in accordance with the Notification of Solicitation (if applicable), Request for Information (if applicable), Request for Bid, Addenda, Contract, Bonds, Insurance, Plans, Specifications, any Instructions, Mandatory Requirements and Conditions.
21. Unless specified elsewhere in the document, all prices quoted must be F.O.B. County destination and will include all delivery, handling, and any other charges related to delivery including surcharges.
22. It will be understood that the bidder's sureties and insurers, as applicable, are subject to the approval of the County.
23. If a vendor is awarded a contract, Domestic (Kansas) corporations shall 1) furnish evidence of good standing in the form of a Certificate signed by the Kansas Secretary of State. Foreign (non-Kansas) corporations shall furnish evidence of authority to transact business in Kansas, in the form of a Certificate signed by the Kansas Secretary of State; and 2) a copy of the Corporation Resolution evidencing the authority to sign the Contract Documents, executed by the Corporation's Secretary or Assistant Secretary.
24. Upon award, the bidder agrees to execute and deliver to the County a contract in accordance with the contract documents (if applicable) within ten days of notice of the award to the bidder. The bidder agrees that the surety/deposit given concurrently herewith will become the property of the County in the event the bidder fails to execute and deliver

such contract within the specified time. In the further event of such failure, the bidder will be liable for the County's actual damages that exceed the amount of the surety.

25. It will be understood that time is of the essence in the bidder's performance. The bidder agrees that the County's damages would be difficult or impossible to predict in the event of a default in the performance hereof; and it is therefore agreed that if the bidder defaults in the performance of the contract documents, the bidder will be liable for payment of the sums stipulated in the contract documents as liquidated damages, and not as a penalty.
26. The bidder hereby certifies that he or she has carefully examined all of the documents for the project, has carefully and thoroughly reviewed this Request for Bid, has inspected the location of the project (if applicable), and understands the nature and scope of the work to be done; and that this bid is based upon the terms, specifications, requirements, and conditions of the Request for Bid documents. The bidder further agrees that the performance time specified is a reasonable time, having carefully considered the nature and scope of the project as aforesaid.
27. It will be understood that any bid and any and/or all referencing information submitted in response to this Request for Bid will become the property of Sedgwick County, and will not be returned. As a governmental entity, Sedgwick County is subject to making records available for disclosure after Board of County Commission approval of the recommendation.
28. Sedgwick County will not be responsible for any expenses incurred by any vendor in the development of a response to this Request for Bid including any onsite (or otherwise) interviews and/or presentations, and/or supplemental information provided, submitted, or given to Sedgwick County and/or its representatives. Further, Sedgwick County will reserve the right to cancel the work described herein prior to issuance and acceptance of any contractual agreement/purchase order by the recommended vendor even if the Board of County Commissioners has formally accepted a recommendation.
29. By submission of a response, the bidder agrees that at the time of submittal, he or she: (1) has no interest (including financial benefit, commission, finder's fee, or any other remuneration) and will not acquire any interest, either direct or indirect, that would conflict in any manner or degree with the performance of bidder's services, or (2) benefit from an award resulting in a "Conflict of Interest". A "Conflict of Interest" will include holding or retaining membership, or employment, on a board, elected office, department, division or bureau, or committee sanctioned by and/or governed by the Sedgwick County Board of County Commissioners. Bidders will identify any interests, and the individuals involved, on separate paper with the response and will understand that the County, at the discretion of the Purchasing Director in consultation with the County Counselor, may reject their bid/quotation. The bidder certifies that this bid is submitted without collusion, fraud or misrepresentation as to other bidders, so that all bids for the project will result from free, open and competitive bidding among all vendors.
30. Sedgwick County will issue a purchase order/contract for the acquisition of products/services specified as a result of an award made in reference to this document. Contract documents will be subject to any regulations governed by the laws of the State of Kansas and any local resolutions specifically applicable to the purchase.
31. Any dispute arising out of the contract documents or their interpretation will be litigated only within the courts of the State of Kansas. No prepayment of any kind will be made prior to shipment. Payment will be made upon verification of delivery, compliance with specifications, assurance that the product/service performs as specified and warranted, and receipt of correct invoicing.
32. Sedgwick County will accept responses transmitted via a facsimile unless stated to the contrary within this document. Bids must be received prior to the time and dates listed to be considered responsive. Sedgwick County will not accept late responses and will return them to the sender. Further, Sedgwick County will NOT: (1) guarantee security of the document received; (2) be held responsible for Bids which are NOT legible (and may choose to reject such responses); and, (3) guarantee that the receiving facsimile machine will accept transmission or that phone lines are functioning and available for transmission. Submitting a bid response via facsimile does NOT relieve the bidder of: (1) responsibilities stated in the document (such as attendance at a mandatory pre-bid conference); (2) providing non-paper informational items which must be returned with the response (diskettes, large drawings, photographs, models, etc.); and, (3) providing original copies of bid sureties (bonds, certificates of insurance, etc.).

SPECIAL PROVISION

ALUMINUM ALLOYS FOR TRAFFIC SIGN BLANKS

DESCRIPTION: This specification covers material and fabrication requirements for aluminum alloys for traffic sign blanks.

REQUIREMENTS: All materials shall conform to the dimensions shown in this specification. Allowable tolerances shall be as specified by ASTM specifications. Sheet aluminum for sign blanks shall be made in accordance with ASTM B209, Alloy 6061-T6 or Alloy 5052-H38.

FABRICATION: The signs to be furnished shall be pressed from flat sheets. The signs shall be cut to the size and shape specified in the bid proposal and as shown in this specification. They shall be free from buckles, warp, dents, cockles, burrs and other defects caused by fabrication.

Sign blank standards included in this specification show required dimensions in inches (mm) for all aluminum sign blanks used by Sedgwick County, Kansas. Sheet thickness shall be determined by the total area of the sign blank. Unless otherwise specified in the bid proposal, sign blanks measuring 9 ft² (0.8 m²) or less shall have a thickness of 0.080" (2 mm), and sign blanks measuring greater than 9 ft² (0.8 m²) shall have a thickness of 0.100" (2.5 mm).

Bolt holes 0.375" (9.5 mm) in diameter shall be drilled as detailed in this specification for each size and shape of sign. The edges of the holes shall be free of burrs and other defects.

Following fabrication, the sign blanks shall be prepared with a chromate, alodine or phosphate etched finish. The metal shall not be handled between the cleaning and etching operation and delivery except by a mechanical device or with clean canvas gloves. There shall be no opportunity for metal to come in contact with grease, oils or other contaminants prior to delivery.

BASIS OF ACCEPTANCE: Acceptance of material furnished under this specification will be based on a certification prepared by the manufacturer showing that test value limits are within ASTM allowances, and a visual inspection upon delivery for condition and conformance with dimensional and other requirements.

DELIVERY: Delivery of the items in this order are essential for the Bureau of Public Services to provide services to the citizens of Sedgwick County. Time is of the essence in the performance hereof. Delivery of this order shall be made within 30 calendar days after receipt of order. Supplier acknowledges that damages would be difficult or impossible to predict in the event of default and, therefore, that for each calendar day that this order shall be overdue, \$75.00 per day shall be assessed as liquidated damages and not as a penalty.

BASIS OF PAYMENT: Payment for aluminum sign blanks shall be made at the contract unit price bid per each sign blank for each size and shape of sign blank delivered less any applicable liquidated damages.

SIGN BLANK STANDARDS

HORIZONTAL RECTANGLE

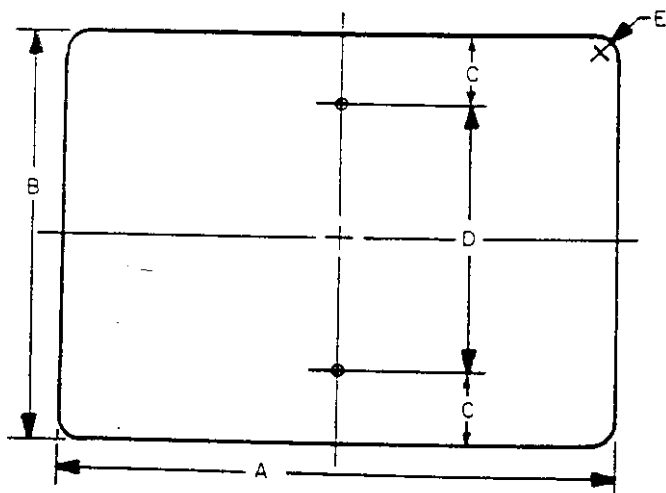

| A | B | C | D | E |
|----|----|-------|----|-------|
| 12 | 6 | 1 1/2 | 3 | 1-1/2 |
| 21 | 15 | 1-1/2 | 12 | 1-1/2 |
| 24 | 12 | 1-1/2 | 9 | 1-1/2 |
| 24 | 18 | 3 | 12 | 1-1/2 |
| 30 | 15 | 1-1/2 | 12 | 1-1/2 |
| 30 | 24 | 3 | 18 | 1-1/2 |
| 36 | 12 | 1-1/2 | 9 | 1-1/2 |

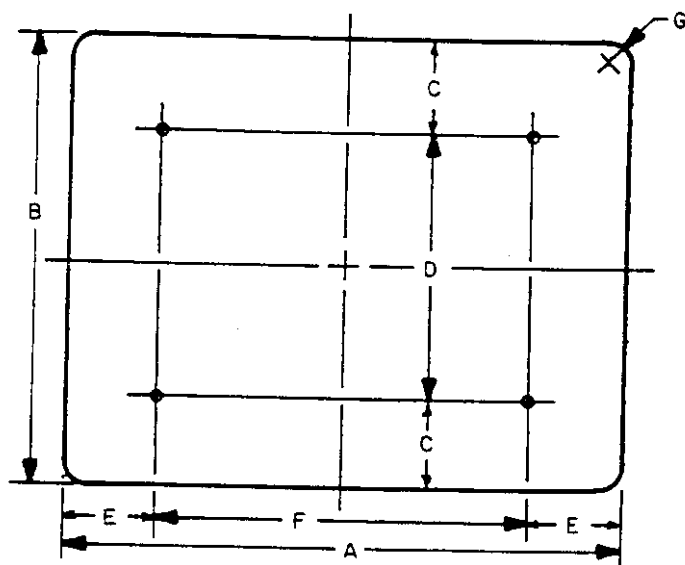

| A | B | C | D | E | F | G |
|----|----|---|----|----|----|-------|
| 36 | 24 | 3 | 18 | 6 | 24 | 1-1/2 |
| 48 | 24 | 3 | 18 | 9 | 30 | 1-7/8 |
| 48 | 30 | 6 | 18 | 9 | 30 | 1-7/8 |
| 48 | 36 | 6 | 24 | 9 | 30 | 2-1/4 |
| 60 | 24 | 3 | 18 | 12 | 36 | 1-1/2 |
| 60 | 36 | 6 | 24 | 12 | 36 | 2-1/4 |

SIGN BLANK STANDARDS

OCTAGON

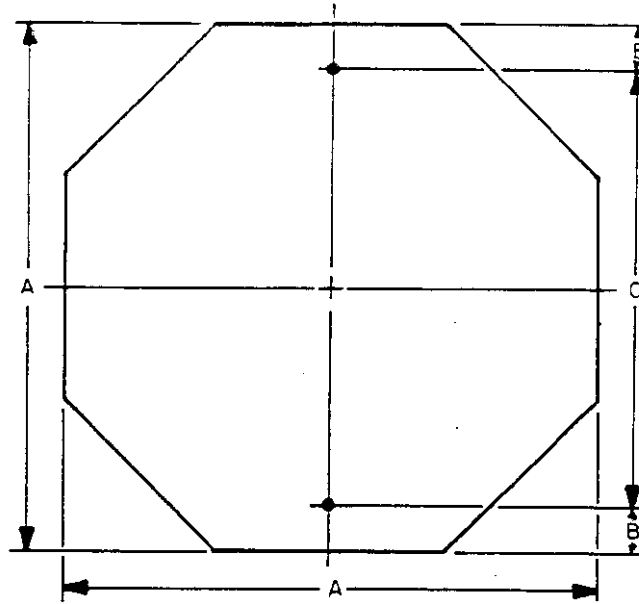

| A | B | C |
|----|---|----|
| 30 | 3 | 24 |
| 36 | 3 | 30 |

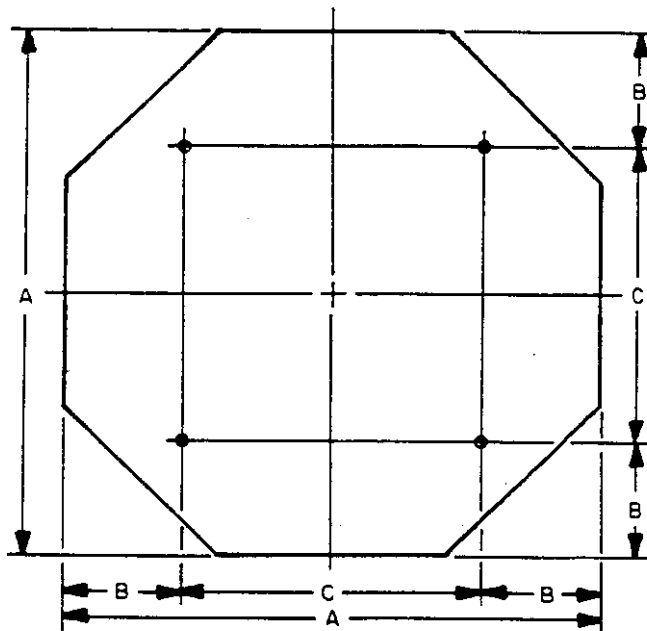

| A | B | C |
|----|---|----|
| 48 | 9 | 30 |

SIGN BLANK STANDARDS

CIRCLE

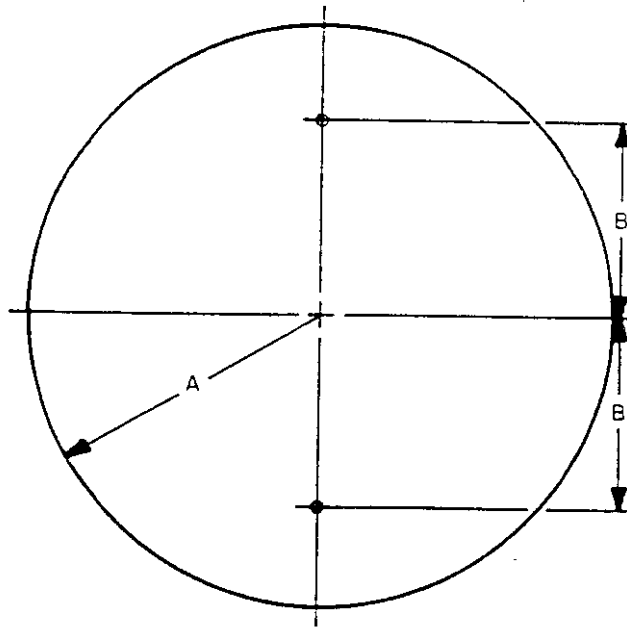

| | |
|----|----|
| A | B |
| 18 | 15 |

ISOSCELES TRIANGLE

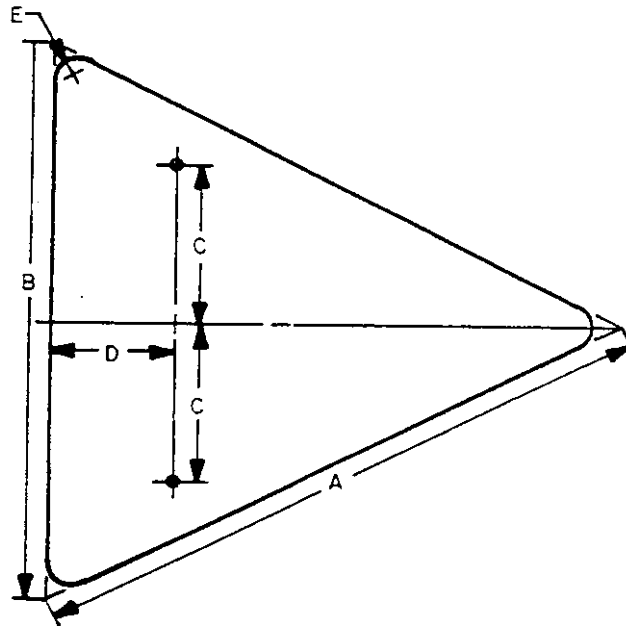

| | | | | |
|----|----|-------|----|-------|
| A | B | C | D | E |
| 40 | 30 | 7-1/2 | 12 | 1-7/8 |
| 48 | 36 | 9 | 15 | 2-1/4 |

PENTAGON (SCHOOL)

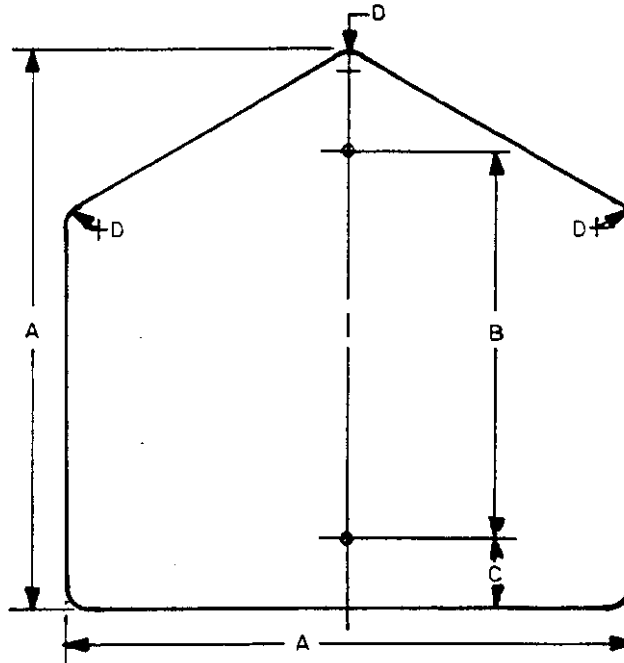

| A | B | C | D |
|----|----|---|-------|
| 30 | 21 | 3 | 1-7/8 |
| 36 | 24 | 3 | 2-1/4 |

STREET NAME

(FLAT BLADE)

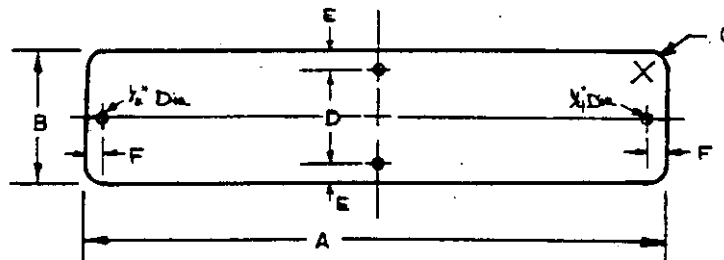

| A | B | C | D | E | F |
|----|----|-------|-----|-------|-------|
| 30 | 9 | 1 1/2 | N/A | N/A | N/A |
| 36 | 9 | 1 1/2 | N/A | N/A | N/A |
| 36 | 12 | 1 1/2 | 9 | 1 1/2 | 1 1/2 |
| 42 | 12 | 1 1/2 | 9 | 1 1/2 | 1 1/2 |
| 48 | 12 | 1 1/2 | 9 | 1 1/2 | 1 1/2 |
| 60 | 18 | 1 1/2 | 12 | 3 | 3 |

NOTE: No holes shall be drilled on 9" tall blanks.

NOTE: All holes shall be 3/8" on 60" long blanks. Also, an additional hole shall be drilled at the center of the 60" blanks.

SIGN BLANK STANDARDS

SQUARE

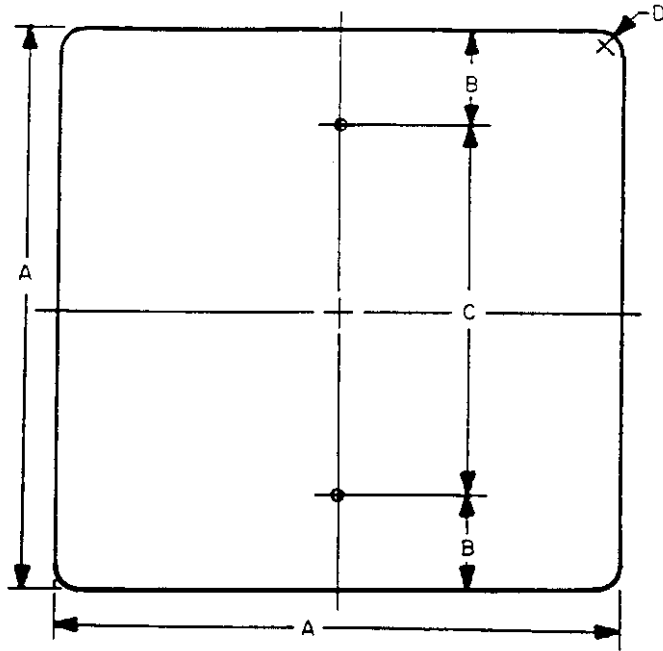

| A | B | C | D |
|----|---|----|-------|
| 12 | 3 | 6 | 1-1/2 |
| 18 | 3 | 12 | 1-1/2 |
| 24 | 3 | 18 | 1-1/2 |
| 30 | 3 | 24 | 1-7/8 |

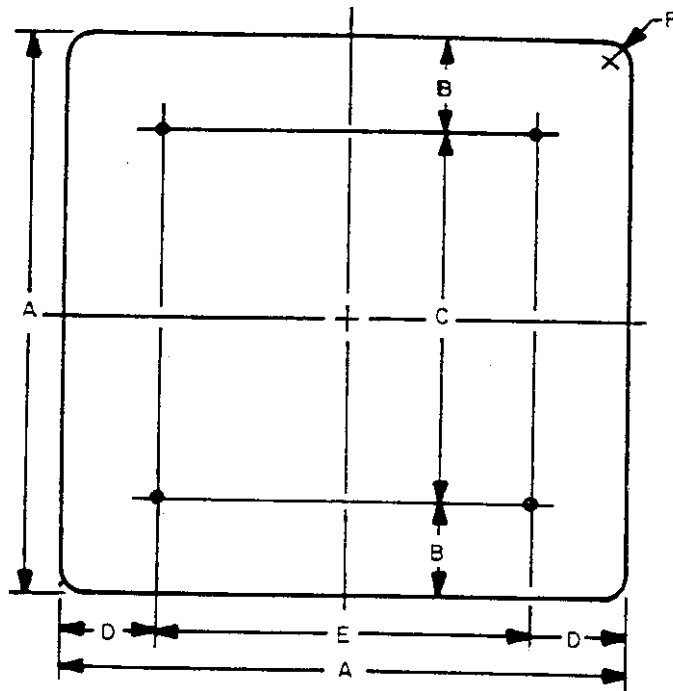

| A | B | C | D | E | F |
|----|---|----|---|----|-------|
| 36 | 6 | 24 | 6 | 24 | 2-1/4 |
| 48 | 6 | 36 | 9 | 30 | 3 |

VERTICAL RECTANGLE

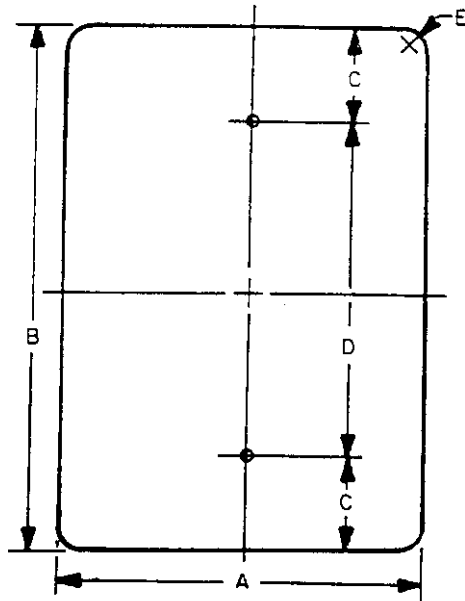

| A | B | C | D | E |
|----|----|-------|----|-------|
| 6 | 12 | 3 | 6 | 1-1/2 |
| 12 | 18 | 1-1/2 | 15 | 1-1/2 |
| 12 | 36 | 6 | 24 | 1-1/2 |
| 18 | 24 | 3 | 18 | 1-1/2 |
| 24 | 30 | 3 | 24 | 1-1/2 |
| 24 | 48 | 6 | 36 | 1-7/8 |
| 30 | 36 | 3 | 30 | 1-7/8 |

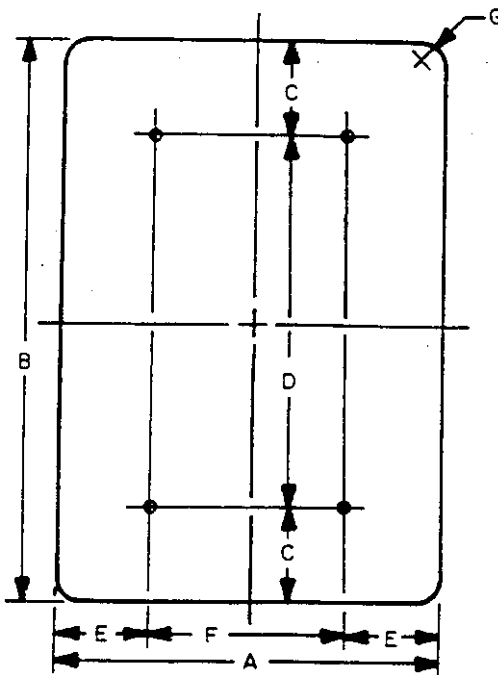

| A | B | C | D | E | F | G |
|----|----|---|----|---|----|-------|
| 36 | 48 | 6 | 36 | 6 | 24 | 2-1/4 |
| 48 | 60 | 6 | 48 | 9 | 30 | 3 |

BID RESPONSE FORM
#09-0154
TRAFFIC SIGN BLANKS

Initial purchase quantity

| Item No. | Quantity | Unit of Measure | Description of Traffic Sign Blanks | Unit Price | Total |
|----------|----------|-----------------|------------------------------------|------------|-------|
| 1. | 1,000 | Each | 36" x 12" STREET NAME | | |
| 2. | 100 | Each | 18" x 18" SQUARE | | |
| 3. | 250 | Each | 30" x 9" STREET NAME | | |
| 4. | 250 | Each | 36" x 9" STREET NAME | | |
| 5. | 100 | Each | 48" x 12" STREET NAME | | |
| 6. | 500 | Each | 12" x 36" VERTICAL RECTANGLE | | |
| 7. | 250 | Each | 24" x 30" VERTICAL RECTANGLE | | |
| 8. | 100 | Each | 42" x 9" STREET NAME | | |
| 9. | 50 | Each | 30" x 30" OCTAGON | | |
| | | | GRAND TOTAL | | |

This bid will constitute contract pricing for one (1) year following award, with the potential for two (2) additional one (1) year options to renew, subject to approval by Sedgwick County.

State brand, product number and send specification sheet with bid for above items requested.

Prices are to be quoted FOB Destination (delivered pricing)

Vendor shall deliver _____ calendar days after receipt of order.

Delivery address: Sedgwick County Public Works (Sign Shop)
 Attn: Jerry Day
 1144 S. Seneca, Building 16
 Wichita, KS 67213
 (316) 304-1175

BID RESPONSE FORM
#09-0154
TRAFFIC SIGN BLANKS

All firms interested in bidding must complete and return one (1) original and two (2) copies of the entire document to the Sedgwick County Purchasing Department at 525 N. Main, Suite 823, Wichita, KS 67203 on or before 1:45 p.m. CDT, Tuesday, June 9, 2009.

The undersigned, on behalf of the Bidder, certifies that: (1) this offer is made without previous understanding, agreement or connection with any person, firm or corporation making a quotation on the same project; (2) is in all respects fair and without collusion or fraud; (3) the person whose signature appears below is legally empowered to bind the firm in whose name the Bid is entered; (4) they have read the complete Request for Bid and understands all provisions; (5) if accepted by the County, this bid is guaranteed as written and amended and will be implemented as stated; and (6) mistakes in writing of the submitted bid will be their responsibility.

FIRM NAME _____

CONTACT _____

SIGNATURE _____ TITLE _____

PRINT NAME _____

ADDRESS _____ CITY/STATE _____ ZIP _____

PHONE _____ FAX _____ HOURS _____

TAX PAYER I.D. NUMBER _____

COMPANY WEB SITE ADDRESS _____ E-MAIL _____

NUMBER OF LOCATIONS _____ NUMBER OF PERSONS EMPLOYED _____

TYPE OF ORGANIZATION: Public Corporation _____ Private Corporation _____

Sole Proprietorship ___ Partnership ___ Minority Business ___ Woman-Owned Business ___ Small Business ___

GENERAL NATURE OF BUSINESS _____

Manufacturer ___ Distributor ___ Retail ___ Dealer ___ Service ___

ACKNOWLEDGE RECEIPT OF ADDENDA: All addendum(s) are posted to our RFQ/RFP web page and it is the vendor's responsibility to check and confirm all addendum(s) related to this document by going to www.sedgwickcounty.org/purchasing.

NO. _____, DATED _____; NO. _____, DATED _____; NO. _____, DATED _____

Yes, I would like to be on the emergency vendor list. No, I would not like to be on the emergency vendor list.

After Hours Phone #: _____ Emergency Contact Name: _____

After Hours Fax #: _____

Does your company accept credit payments? Yes No

In submitting a response to this document, vendor acknowledges acceptance of all sections of the entire document and has clearly delineated and detailed any exceptions.

Contract Pricing
This bid will constitute contract pricing for one (1) year following award, with the potential for two (2) additional one (1) year options to renew, subject to approval by Sedgwick County. An official Purchase Order will be provided to the successful vendor.

Signature _____ Title _____

Date _____