

ADDENDUM NO. 1

Sedgwick County Project: Dry Creek Estates; Street Improvements

The items contained herein now become a part of the referenced plans and specifications. Please read the following items and acknowledge receipt of this addendum on the Proposal Page Number P-1. NOTE: THIS ADDENDUM MUST BE ACKNOWLEDGED TO CONSTITUTE A VALID BID.

PLANS:

- Sheet 8R: Corrected shoulder width to read “3.5’ AS-1 Rock Shoulders” at east end of Shade Street
- Sheet 11R: Corrected shoulder width to read “3.5’ AS-1 Rock Shoulders” on Talia Street
- Sheet 16R:
 - a. Provided Light Stone Riprap Detail. Toe Walls and 6” Stone Filter Course Backing shall be subsidiary to “Riprap (Light Stone).”
 - b. Adjusted plan callout for Light Stone Riprap to reference detail on “This Sheet.”
- Sheet 27R: Corrected references for Light Stone Riprap to read “RE: SHEET 16R.”

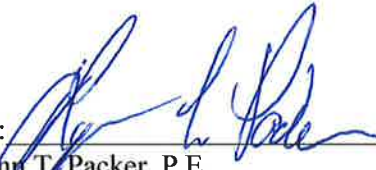
By: 

Lynn T. Packer, P.E.
Director of Public Works/County Engineer

Date: June 15, 2023

FILE LOCATION: C:\Users\User2\OneDrive - CED\Projects\2022\20223179\DWG\Erosion.dwg TAB NAME: Pond Plan USER: User2 SAVED: 6/14/2023 10:37 AM PLOTTED: 6/14/2023 10:38 AM

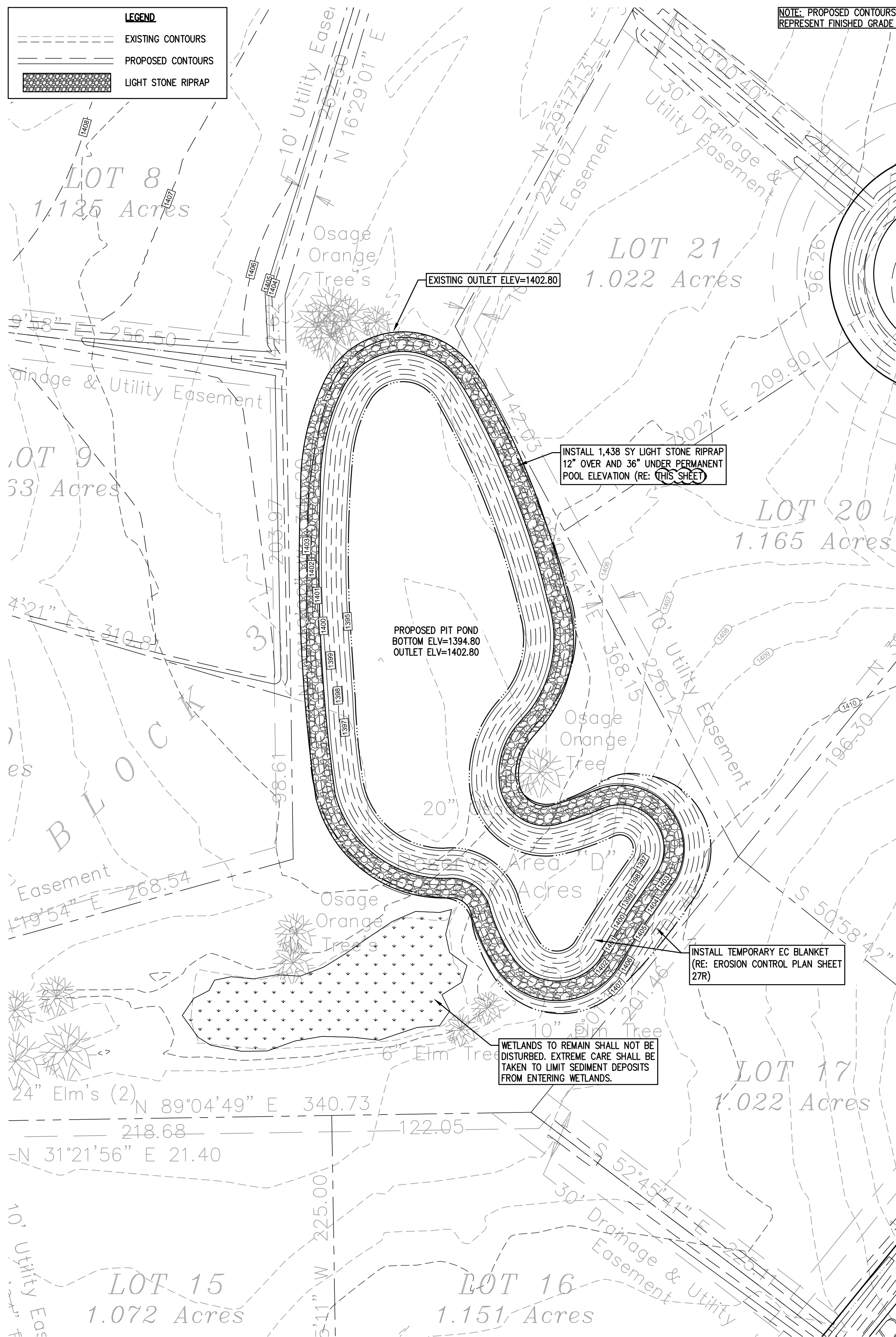

NOTE: PROPOSED CONTOURS REPRESENT FINISHED GRADE

LEGEND	
	EXISTING CONTOURS
	PROPOSED CONTOURS
	LIGHT STONE RIPRAP

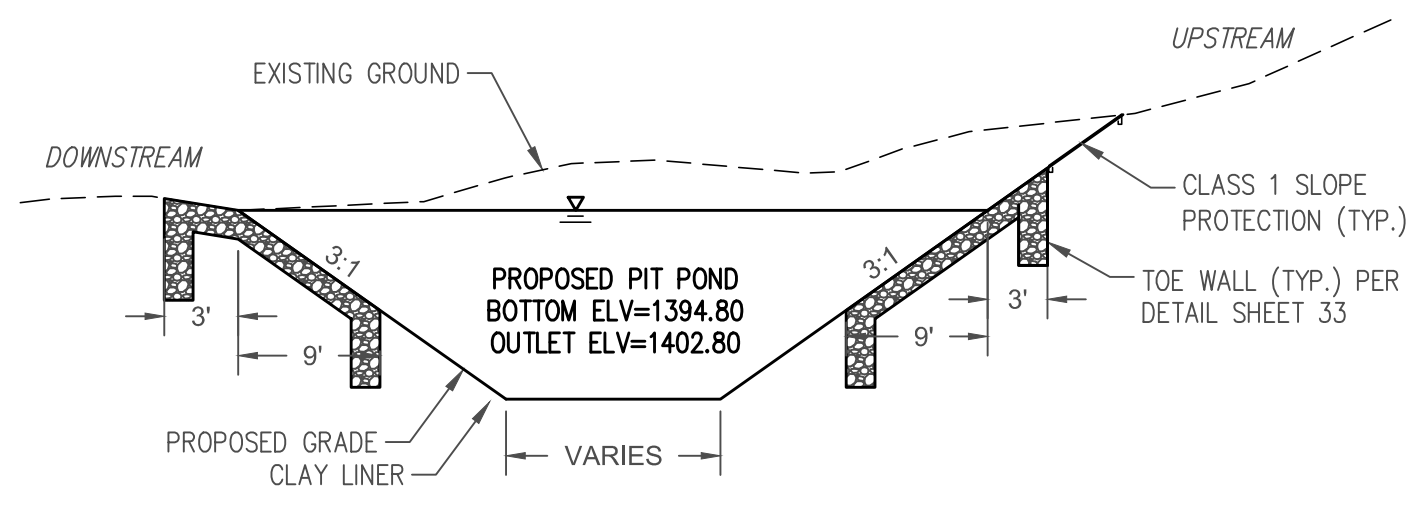

PROPOSED PIT POND - TYPICAL SECTION (NOT TO SCALE)

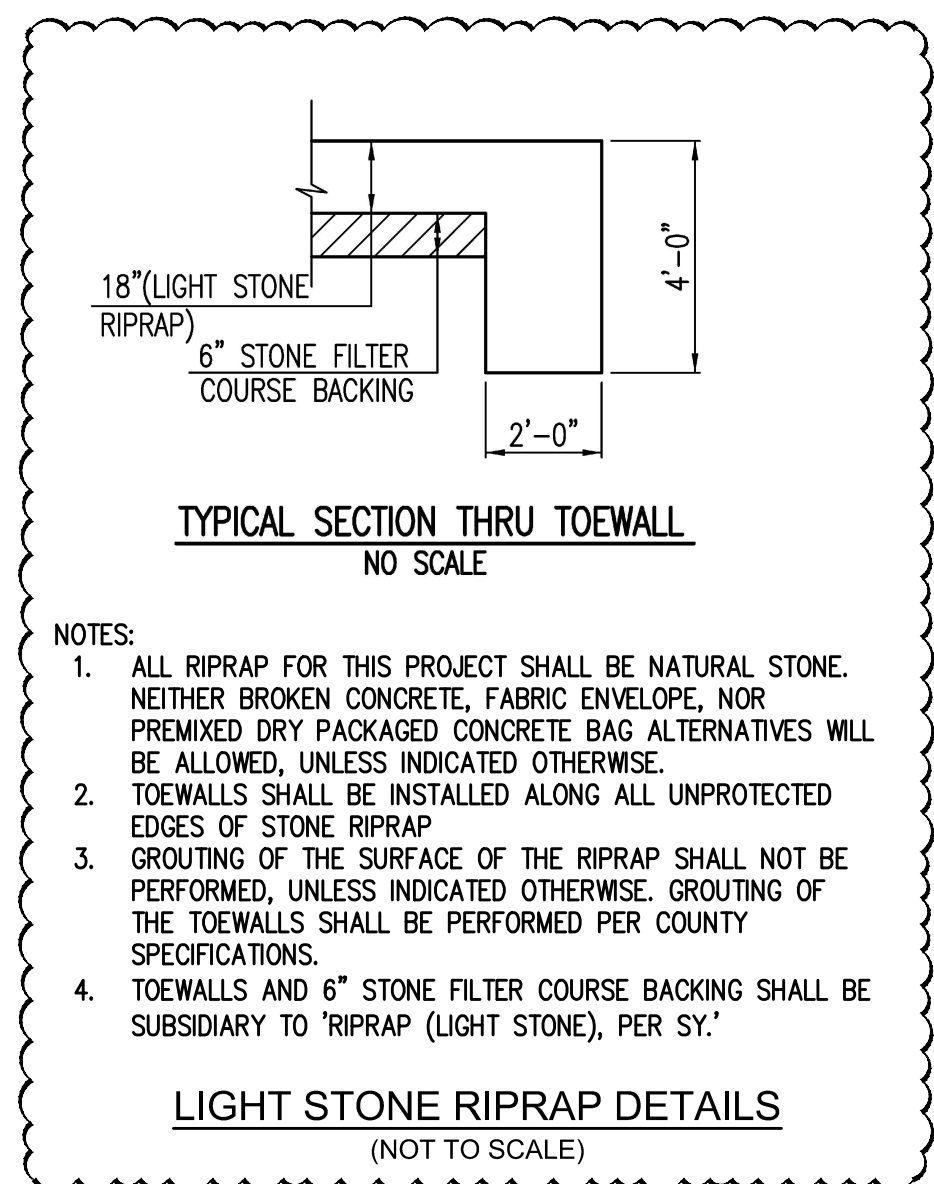

LIGHT STONE RIPRAP DETAILS (NOT TO SCALE)

- NOTES:
1. ALL RIPRAP FOR THIS PROJECT SHALL BE NATURAL STONE. NEITHER BROKEN CONCRETE, FABRIC ENVELOPE, NOR PREMIXED DRY PACKAGED CONCRETE BAG ALTERNATIVES WILL BE ALLOWED, UNLESS INDICATED OTHERWISE.
 2. TOEWALLS SHALL BE INSTALLED ALONG ALL UNPROTECTED EDGES OF STONE RIPRAP.
 3. GROUTING OF THE SURFACE OF THE RIPRAP SHALL NOT BE PERFORMED, UNLESS INDICATED OTHERWISE. GROUTING OF THE TOEWALLS SHALL BE PERFORMED PER COUNTY SPECIFICATIONS.
 4. TOEWALLS AND 6" STONE FILTER COURSE BACKING SHALL BE SUBSIDIARY TO RIPRAP (LIGHT STONE), PER SY.

- POND NOTES
1. POND BOTTOM AND SIDE SLOPES BELOW STATIC POOL SHALL BE OVEREXCAVATED BY 1' AND A 1' CLAY LINER SHALL BE COMPACTED TO 95% STD. DENSITY. THE PLASTICITY INDEX (PI) SHALL BE AT LEAST 20. THE COMPACTION SHALL BE VERIFIED DURING CONSTRUCTION. COST SUBSIDIARY TO OTHER ITEMS OF WORK IN THE CONTRACT.
 2. ALL DISTURBED AREA ABOVE THE POND STATIC POOL SHALL BE SEEDED, FERTILIZED AND MULCHED. SEE EROSION CONTROL PLAN.
 3. INSTALL EROSION CONTROL MAT BELOW ELEVATION 1399.80, EXCLUDING POND BOTTOM. SEE EROSION CONTROL PLAN.

SURVEY DISCLAIMER:
 TOPOGRAPHIC SURVEY USED IN PREPARING PLANS WAS DEVELOPED AND PROVIDED SOLELY FOR ENGINEER PLANS. ENGINEER DOES NOT GUARANTEE SURVEY ELEVATIONS FOR ACCURACY. CONTRACTOR SHALL VERIFY ELEVATIONS AND NOTIFY ENGINEER OF ANY DISCREPANCIES.

UTILITIES SHOWN REPRESENT THE BEST INFORMATION AVAILABLE FOR DESIGN. ADDITIONAL UTILITIES MAY BE PRESENT ON THIS PROJECT. THE CONTRACTOR SHALL BE RESPONSIBLE FOR DETERMINING THE EXACT LOCATION, DEPTH AND SIZE OF ALL UNDERGROUND UTILITIES PRIOR TO CONSTRUCTION. THE CONTRACTOR SHALL BE LIABLE FOR ANY DAMAGE CAUSED BY THE FAILURE TO DO SO.

REV.	DESCRIPTION	DATE
1	ADDENDUM	6/14/23

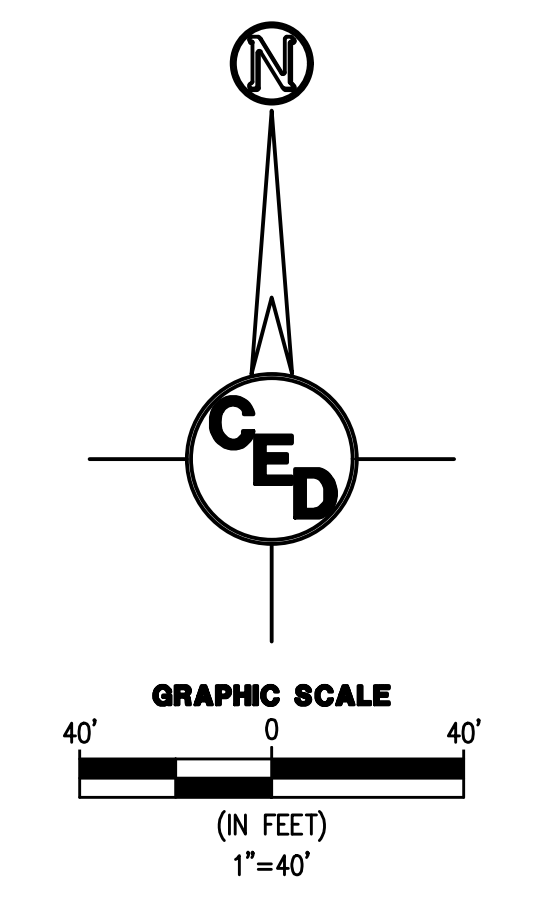

DRY CREEK ESTATES STREET IMPROVEMENTS

S 1/2 OF THE NW 1/4, S22-T27S-R2W
 SEDGWICK COUNTY, KS

CERTIFIED ENGINEERING DESIGN, P.A.
 CIVIL ENGINEERING SERVICES



1935 WEST MAPLE STREET
 WICHITA, KANSAS 67213
 PH.(316)262-8808 FAX.(316)262-1669

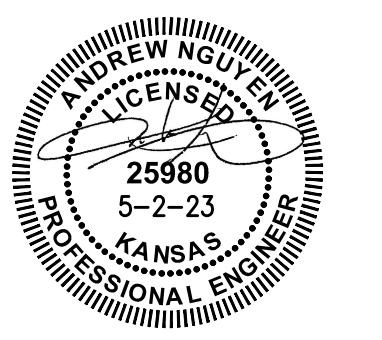

PROJECT NO.: 20223179
 ISSUE DATE: 5/2/2023
 CONTACT: H. FORAKER / L. MILLS
 CHECKED BY: H. FORAKER / L. MILLS



POND PLAN

FILE LOCATION: C:\Users\User2\OneDrive - CED\Projects\2022\20223179\DWG\Erosion.dwg TAB NAME: Erosion USER: User2 SAVED: 6/14/2023 10:37 AM PLOTTED: 6/14/2023 10:38 AM

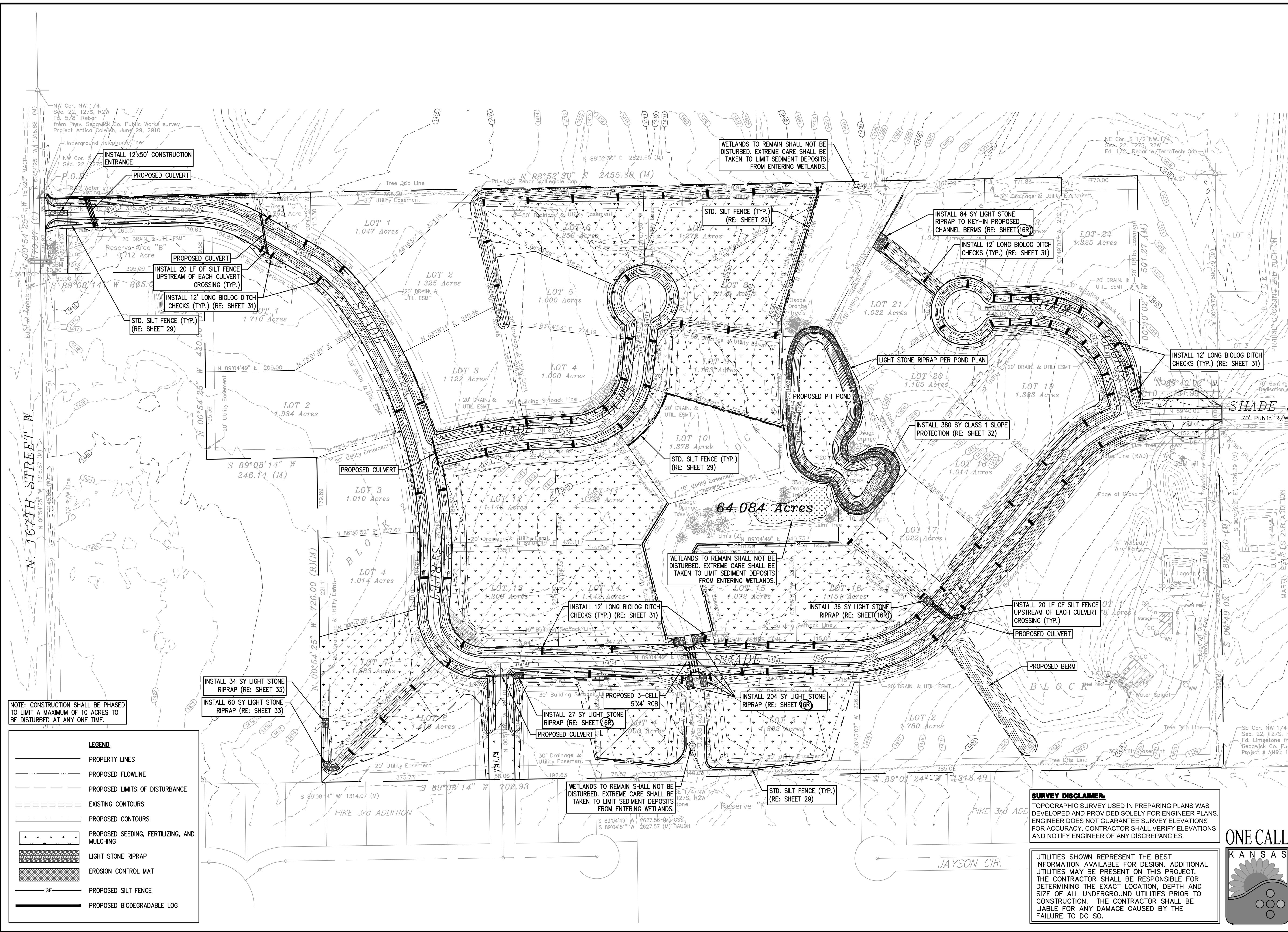

NOTE: CONSTRUCTION SHALL BE PHASED TO LIMIT A MAXIMUM OF 10 ACRES TO BE DISTURBED AT ANY ONE TIME.

LEGEND	
	PROPERTY LINES
	PROPOSED FLOWLINE
	PROPOSED LIMITS OF DISTURBANCE
	EXISTING CONTOURS
	PROPOSED CONTOURS
	PROPOSED SEEDING, FERTILIZING, AND MULCHING
	LIGHT STONE RIPRAP
	EROSION CONTROL MAT
	PROPOSED SILT FENCE
	PROPOSED BIODEGRADABLE LOG

SURVEY DISCLAIMER:
 TOPOGRAPHIC SURVEY USED IN PREPARING PLANS WAS DEVELOPED AND PROVIDED SOLELY FOR ENGINEER PLANS. ENGINEER DOES NOT GUARANTEE SURVEY ELEVATIONS FOR ACCURACY. CONTRACTOR SHALL VERIFY ELEVATIONS AND NOTIFY ENGINEER OF ANY DISCREPANCIES.

UTILITIES SHOWN REPRESENT THE BEST INFORMATION AVAILABLE FOR THIS PROJECT. THE CONTRACTOR SHALL BE RESPONSIBLE FOR DETERMINING THE EXACT LOCATION, DEPTH AND SIZE OF ALL UNDERGROUND UTILITIES PRIOR TO CONSTRUCTION. THE CONTRACTOR SHALL BE LIABLE FOR ANY DAMAGE CAUSED BY THE FAILURE TO DO SO.



REV.	DESCRIPTION	DATE
1	ADDENDUM	6/14/23

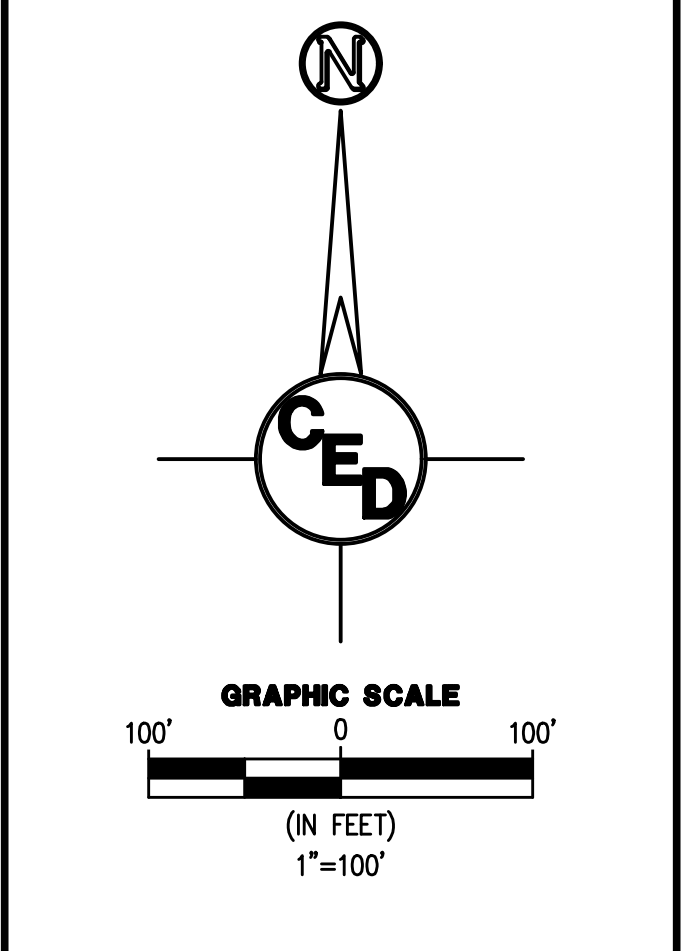

DRY CREEK ESTATES STREET IMPROVEMENTS
 S 1/2 OF THE NW 1/4, S22-T27S-R2W
 SEDGWICK COUNTY, KS

CERTIFIED ENGINEERING DESIGN, P.A.
 CIVIL ENGINEERING SERVICES



1935 WEST MAPLE STREET
 WICHITA, KANSAS 67213
 PH.(316)262-8808 FAX.(316)262-1669

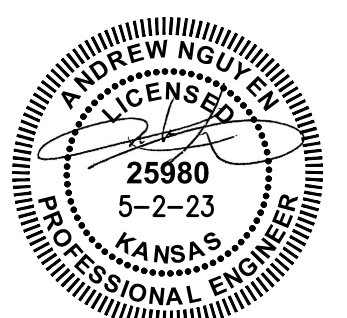

PROJECT NO.: 20223179
 ISSUE DATE: 5/2/2023
 CONTACT: H. FORAKER / L. MILLS
 CHECKED BY: H. FORAKER / L. MILLS

EROSION CONTROL PLAN